

Installing Equipment for the Hydric Soil Technical Standard

Mike Vepraskas, NC State Univ.

April 2005

Procedure:

1. **Sites:** Select at least two spots to monitor. One should be within a hydric soil, or at a spot that is most likely to be hydric. The other should be outside the potential hydric boundary, or is in a questionable location. Equipment at any site should be installed at the same elevation.

2. **Well:** Install the well to a depth of 36 inches. Note that this depth was selected because the tubes could be transported easily.

- a. Auger a hole to 36 in.
- b. Insert well
- c. Back-fill hole with sand to cover the slits in the well.
- d. Place a layer of bentonite pellets (one inch thick) to cover sand
- e. Fill remainder of hole with soil, and form a mound of soil around the well, above the surface, that slopes away from the well.

3. **Shallow Piezometers:** Install one piezometer to a depth of 10 in. The technical standard requires two of these be installed, but in the interest of time we will only install one.

- a. Auger a hole to 10 in.
- b. Insert the piezometer
- c. Back-fill hole with sand only to cover the slits in the piezometer
- d. Cover the sand with a layer of bentonite pellets (one inch thick)
- e. Fill remainder of hole with soil, form a mound of soil around the tube, above the surface, that slopes away from the tube.
- f. Slide a tape measure into the piezometer and measure the depth to the water surface. Subtract the height of the tube above ground from the reading.

4. **Deep Piezometers:** The technical standard calls for two of these to be install to a depth of approximately 36 inches. This won't be done today in the interest of time.

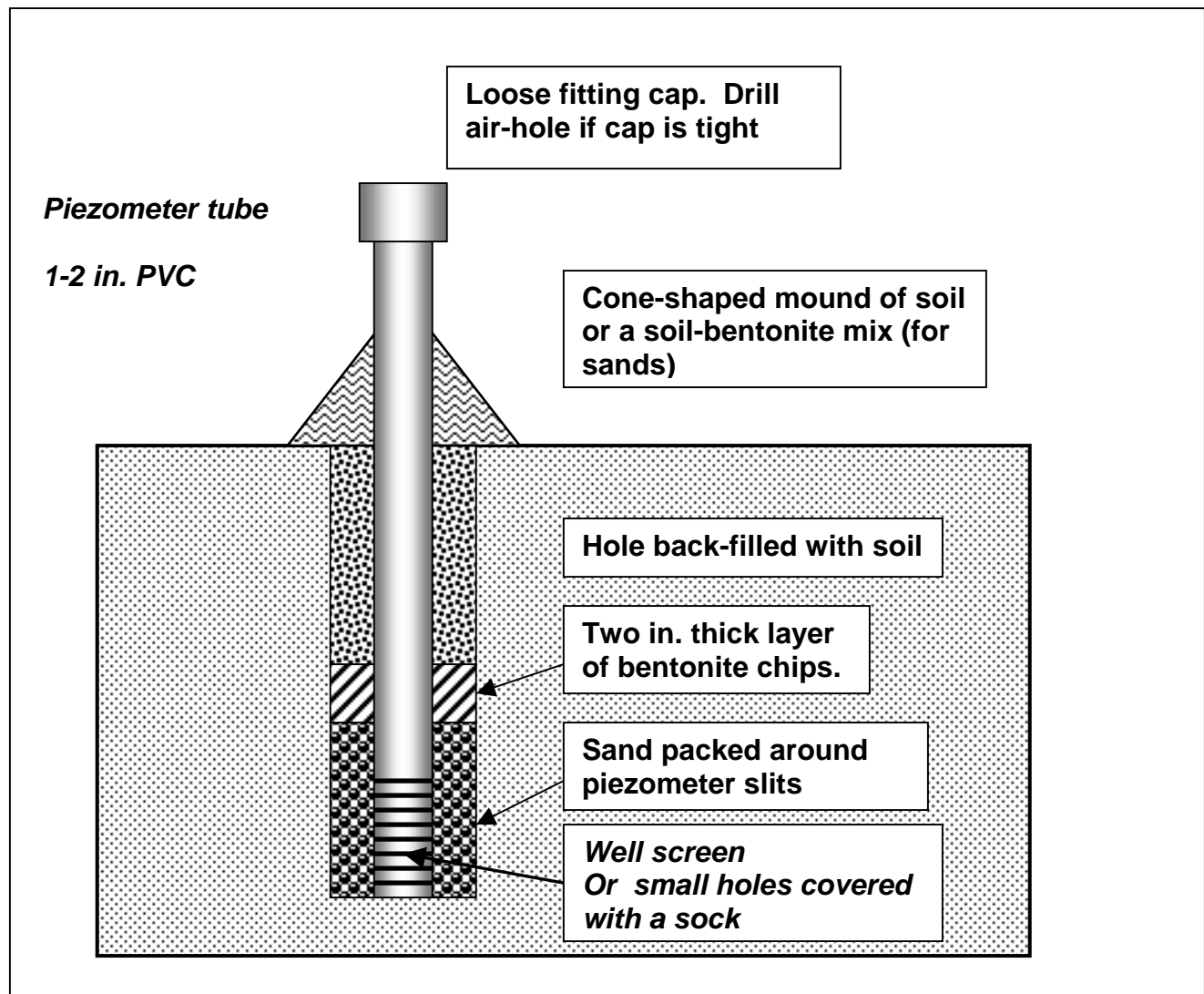

Installing Wells and Piezometers

1. Auger hole to required depth.
2. In clays, scrape sides of hole if walls have smeared
3. Insert well or piezometer
4. Cover slits in tube with sand, and tamp sand in.
5. Cover sand with 2-in. layer of bentonite chips (don't wet)
6. Fill remainder of hole with soil, tamp in.
7. Form cone at surface made from soil, or soil:bentonite mix (for sands)
8. Install loose cap, or if cap is tight be sure air hole is installed.

Testing: When tubes contain water, pump water out several times to be sure tubes fill and soil is not plugged.

5. **Thermocouple:** Soil temperature measurements made at a depth of 20 inches remain constant throughout the day and the temperature is approximately the average daily soil temperature. When the average daily soil temperature is >5 C or 42 F, microbes should be active. To install a thermocouple or other temperature probe:

- a. Auger a hole to 20 in.
- b. Insert the probe tip into the soil at 20 in.
- c. Back-fill the hole with soil, leaving the wires for the probe above ground

Temperature Readings:

Thermocouples are read with a special meter, which is a modified voltmeter. One wire of the thermocouple is copper, while the other is “constantin” which is silver colored because it is an alloy of copper and tin.

To measure temperature:

- a. Connect the copper wire to one slot of the meter, and the constantin wire to the other slot. The slot for the constantin wire is wider than for the copper, so make sure you get the wires in the right place.
- b. Turn the meter on and read the temperature.

6. **Dye:** The dye is used to detect reduced Fe in the soil. It is a clear solution in the bottle, but when it comes in contact with reduced Fe it turns bright red. It can only be used in the field on samples that are saturated with water.

- a. Pull a sample of soil using an auger or spade from a depth within 10 in. of the surface.
- b. Expose soil that has not be in contact with the metal parts of the auger or spade.
- c. Squirt on the dye and look for a reaction.
 - If the dye turns red, the reduced Fe is present and the soil is anaerobic
 - If the dye does not turn color, then reduced Fe is not present.

7. **Redox Potential:** This is an electrical measurement of voltage that can be used to determine if the soil is anaerobic or not. You will install five platinum electrodes, a reference electrode, and will measure the voltage between the reference electrode and each platinum electrode.

Testing the Equipment

- a. Brush the platinum wires with steel wool to clean them.
- b. Insert the clean electrodes into the test solution
- c. Insert the reference electrode (remove black cap covering ceramic tip)
- d. Connect black wire to “common” terminal on voltmeter and attach to reference electrode
- e. Connect red wire to “volt” terminal on volt meter and connect to a platinum electrode.
- f. Turn meter on, and read voltage. Record voltage
- g. If voltage is within 20 mv of the number on the test solution bottle, the electrodes and the rest of the equipment is okay. If voltage is too high or low, contact the instructor.

Installing Platinum Electrodes

There are different ways for doing this, we will use one that generally works well. It uses a mud slurry made from the topsoil of the soil being studied to seal the electrodes from air.

- a. Auger five holes to a depth of 9.5 in. using a push-probe. Holes should be about 12 in. apart and are generally put in a line.
- b. Fill each hole with a mud slurry made from the topsoil. Don't use the subsoil material below 10 in. because it will have different chemical properties than the topsoil.
- c. Insert one electrode into a filled hole and push to the bottom of the hole. Try to seat the platinum into natural soil at the bottom of the hole, but don't push so hard you bend the wire.
- d. Pour more slurry around the wire to keep the hole filled.
- e. Make one more hole to a depth of 5 in. but do not put slurry into it. This will be for the reference electrode. It should be placed about halfway along the line of platinum electrodes, about 12 inches from the middle electrode.

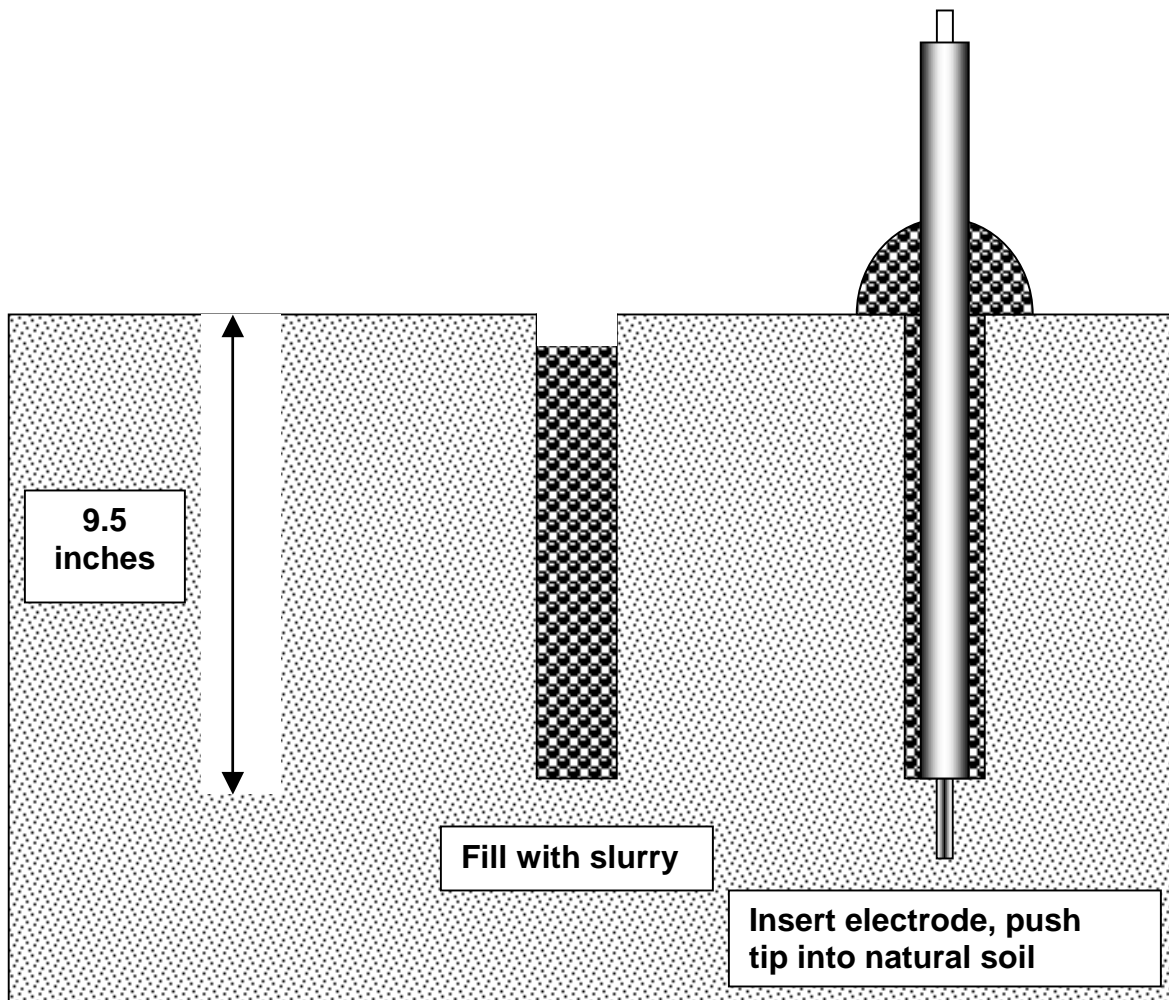

Steps used to install platinum electrodes

1. Auger 1-in. diameter hole to about 9.5 in.
2. Fill hole with slurry made from horizon
3. Insert electrode and push tip into natural soil

Take first reading after 24 hrs.

Reading the Electrodes

- a. Place some water in the open hole, dug to 5 inches, and insert the reference electrode. Be sure you took off the black plastic cap to expose the ceramic tip.
- b. Connect the black wire from the voltmeter (common terminal) to the reference electrode.
- c. Connect the red wire to one platinum electrode.
- d. Turn the meter on, and wait for the readings to stabilize.
- e. Record the voltage. Note whether the voltage is “plus” or “minus”.
- f. Convert the voltage to “Eh” or redox potential by adding **200 mv** to the voltage reading.

8. *pH Measurements:*

A pH value is needed to determine if the soil is anaerobic. Measure pH with the kits using soil collected from a depth of 10 in. with a push probe. Directions for measuring pH are enclosed in the kit.

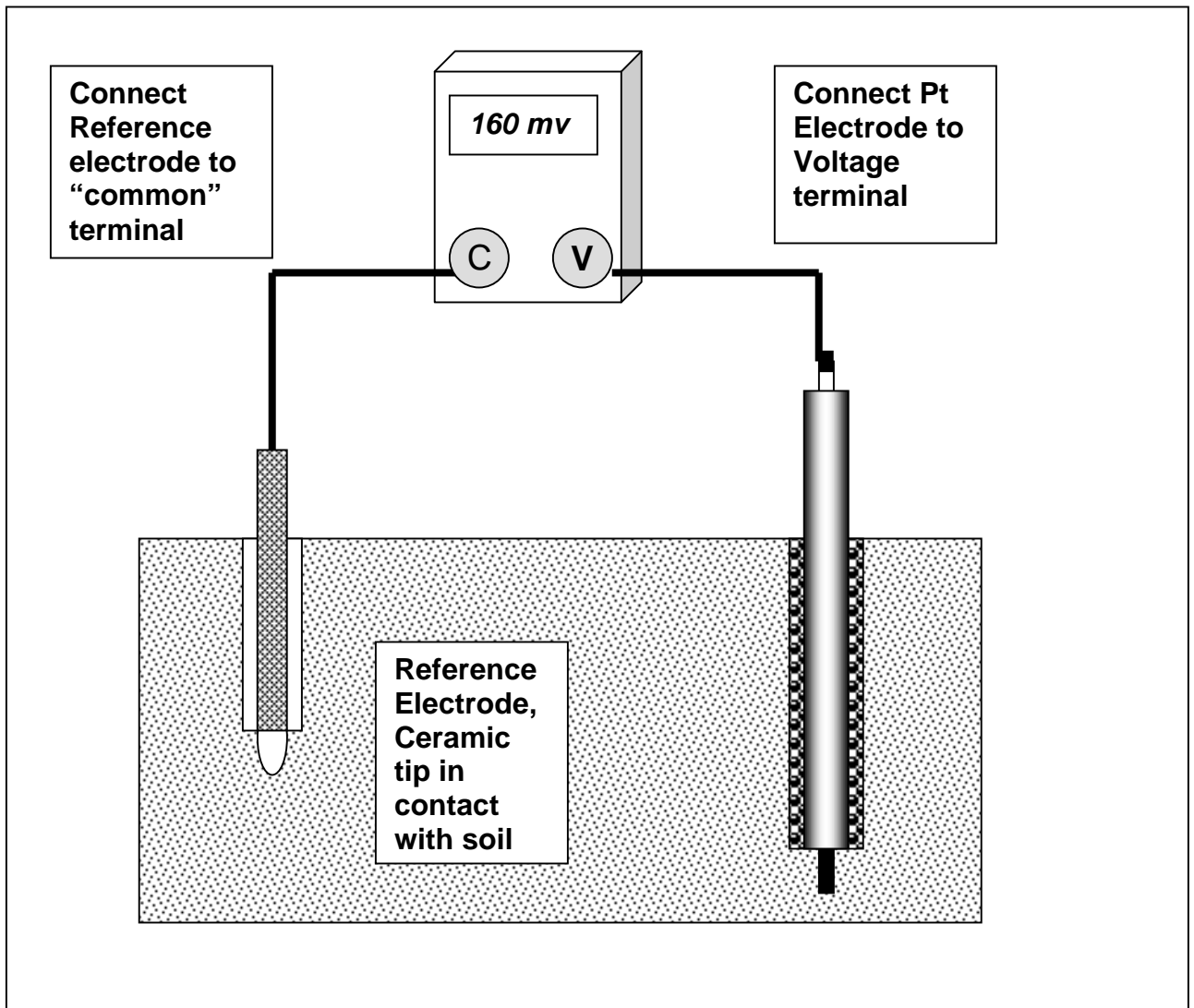

Connecting Electrodes to Voltmeter

1. For reference electrode, auger hole about 2 in. deep and fill with water.
2. Remove plastic cover on reference electrode's tip.
3. Fill hole with water and insert electrode so tip is in contact with soil.
4. Connect reference electrode's wire to "common" terminal of voltmeter.
5. Connect platinum electrode's wire to "voltage" terminal of voltmeter.

Data Interpretation

Redox Potential: Determine whether the soil at each electrode tip is “aerobic” or “anaerobic”. Identify the appropriate Eh value the separates the aerobic and anaerobic conditions using the the soil pH and the following table. **Circle the Eh value for your soil pH.**

Soil pH Value	Eh Value Needed for Anaerobic Conditions
4.0	355 mv
4.5	325
5.0	295
5.5	265
6.0	235
6.5	205
7.0	175
7.5	145
8.0	115

Data Summary Table

Electrode No.	Redox Potential (mv)		Redox State of Soil at Electrode Tip	Overall Soil Condition of Soil (Circle One)
	Field Voltage	Corrected Eh	Aerobic or Anaerobic?	
1				<i>Aerobic</i> <i>Anaerobic</i> Condition based on 3 out of 5 electrodes
2				
3				
4				
5				

Soil Temperature: _____

Depth to Free Water in Piezometer: _____

Depth to Free Water in Well: _____

Use of IRIS Tubes for Hydric Soil Evaluation

Mike Vepraskas
19 April 2005

I. Overview of IRIS Tubes

A. Description

1. An IRIS tube is a PVC pipe that is coated with an iron hydroxide paint. The paint will dissolve in soils that are anaerobic.
2. For evaluating Hydric soils the iron hydroxide paint must cover a section of pipe that is 12 inches long.
3. Tubes must be constructed using only a single layer of paint. The concentration of iron in the paint must match that used by Dr. Byron Jenkinson (bjenkins@dcwi.com).

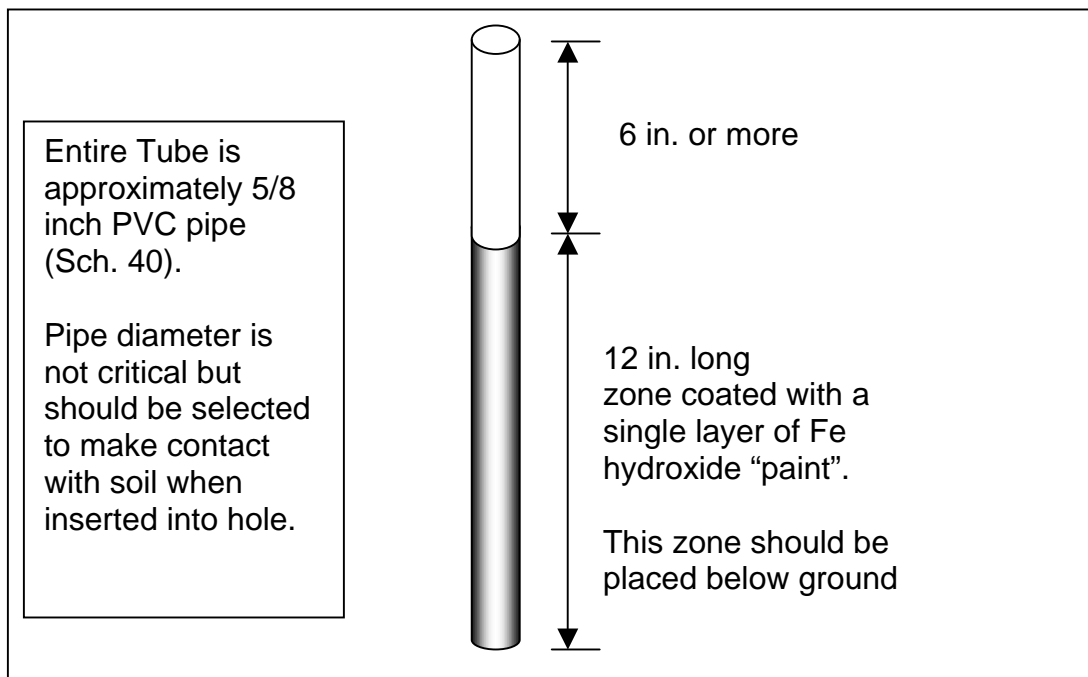

- B. IRIS tubes may be used in two ways for hydric soil evaluation:
- a. To test whether a soil meets the Hydric soil technical standard (See Technical Standard Use).
 - b. As a guide for whether soils in remote locations could be Hydric soils (see Reconnaissance Use in Remote Sites). This procedure does not confirm whether a soil is Hydric but only indicates whether additional testing is warranted.

II. Technical Standard Use

A. Replication and Inspection Frequency:

1. Insert 5 tubes per plot. Tubes must be in contact with undisturbed soil. Plot size and tube spacing are variable but periods of saturation should be the same across the plot, as might be found within a single depression. Plot area may be 6 ft. x 6 ft., and tubes may be up to 3 ft. apart.
2. Tubes should be inspected during periods the soil is saturated, flooded, or ponded to quantify the amount of Fe removed. Inspection must be during a single continuous periods of saturation, flooding, or ponding.

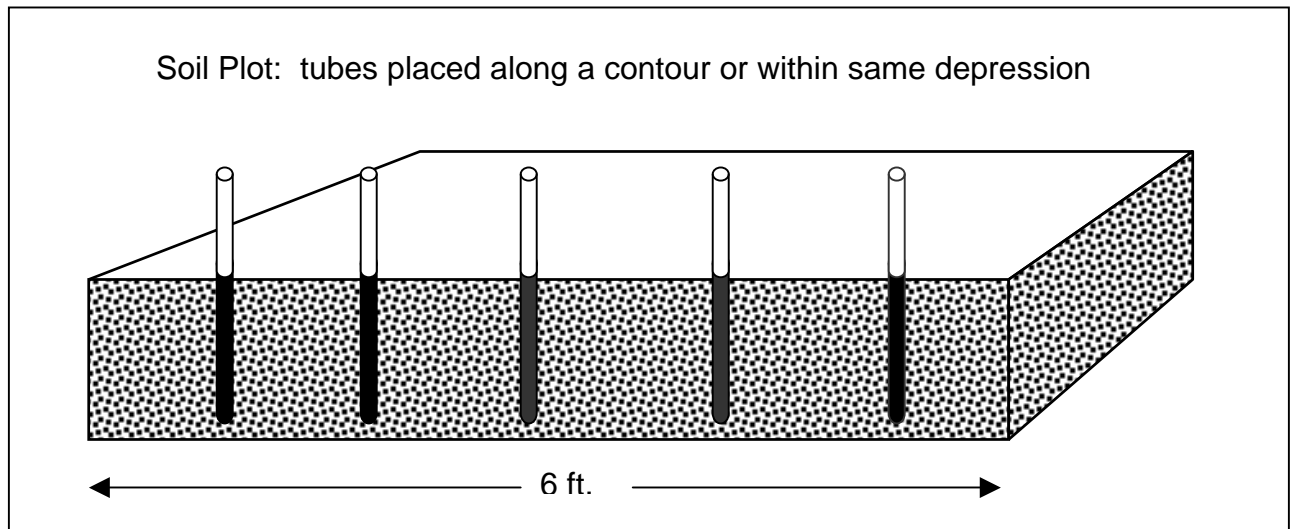

B. Assessing Fe Removed

1. Fe must be removed to the extent that the original color of the PVC pipe is exposed. In most cases the zones from where Fe was removed will appear as white spots.
2. The percentage of area showing Fe removal may be estimated by eye.
3. The minimum area of pipe surface that must show Fe removal will be 6 inches long, and include the entire circumference of the pipe.

C. Evaluation

1. Soils with high water tables:
 - a. Soil will be considered anaerobic when three out of five tubes have Fe removed from 30% of a zone that is 6 inches long.
 - b. Top of the zone of Fe removal must be within 6 inches of soil surface for all textures
2. Ponded or flooded soils:
 - a. Soil will be considered anaerobic when three out of five tubes have Fe removed from 30% of a zone that is 2 inches long.
 - b. Top of the zone of Fe removal must be within 4 inches of soil surface for all textures.

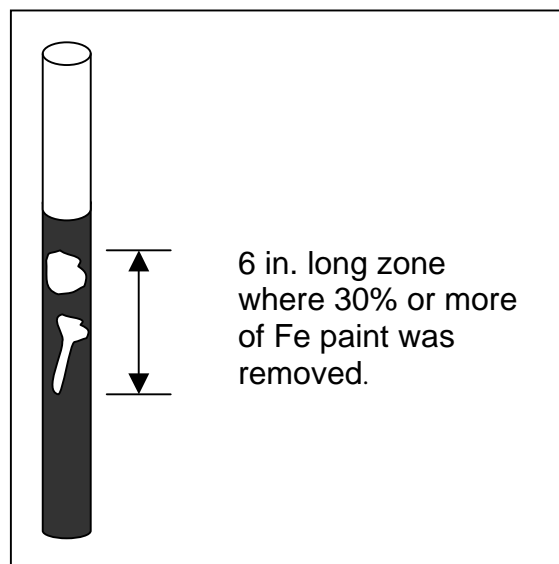

D. Time for Fe Removal

1. Anaerobic conditions must occur during a time the soil is saturated, flooded, or ponded.
2. Time required for 30% Fe removal to occur is not specified but must occur during a time of continuous saturation, flooding or ponding.
3. Saturation durations:
 - a. For all soils other than Vertisols in TX and LA:
Saturation must occur for a continuous period of 14 d.
 - b. For Vertisols in TX and LA:

Saturation, flooding, or ponding must occur for continuous periods of at least 7 d, and a cumulative total of saturation must be 28 d.

III. Reconnaissance Use in Remote Sites

A. Overview

1. IRIS tubes may be used, without measurements of saturation, to assess the likelihood that soils in remote locations will meet the hydric soil technical standard. This assessment is intended as a guide to whether full evaluation of the soils for hydric conditions is warranted.

B. Procedure

1. Insert 5 tubes per plot
2. Estimate the percentage of Fe removal, as described above, at a convenient interval of time which can range from 1 to 3 months between visits.
3. If at the end of the evaluation period, the percentage of Fe removal over the appropriate depth and area of pipe (as described above) is:
 - a. 30% or more: Hydric soil conditions may exist, and retesting for Hydric soil conditions using the technical standard procedure is recommended.
 - b. 10% or less: Hydric soil conditions are not likely
 - c. 10 to 30%: Hydric soil conditions may or may not be present, and a longer period of monitoring is necessary.

Does This Soil Meet Hydric Soil Conditions?

Circle either “yes” or “no” for each of the following questions

1. Is the soil saturated within 10 inches of the surface?

Yes—if there is free water in the shallow piezometer

No—if there is no water in the piezometer

2. Was there a positive reaction to the dye?

Yes—it turned red

No—it didn't turn red

3. Was the soil anaerobic?

Yes—three out of five Eh values were in the *anaerobic range*

No—three out of five Eh values were in the aerobic range

Conclusion: To meet hydric soil requirements you must be able to answer “Yes” to each of the previous three questions.

Did this soil meet hydric soil conditions as specified by the Technical Standard?

Yes

No

If the soil did not meet hydric soil conditions today, why didn't it?

A. Soil was not saturated?

B. Soil temperature was too cold for microbes?

C. Soil was saturated but contained too much oxygen, and hence it wasn't anaerobic (an oxyaquic condition)